

SigCom's **Sentry** Station Cover is a rugged, poly-carbonate cover (UV stabilized) used to help protect manual pull stations from accidental or malicious false alarms, vandalism, dust and weather. It is available in a variety of configurations to satisfy most requirements.

The Front Cover is used with all applications and can protect most flush mounted pull stations. If a surface mount pull station is used, then the Extender is added to the Front cover.

The Backplate can be added to provide a flat mounting area for surface mount boxes on a rough textured wall. This is also needed when the Weather Proof Kit is used for proper sealing.

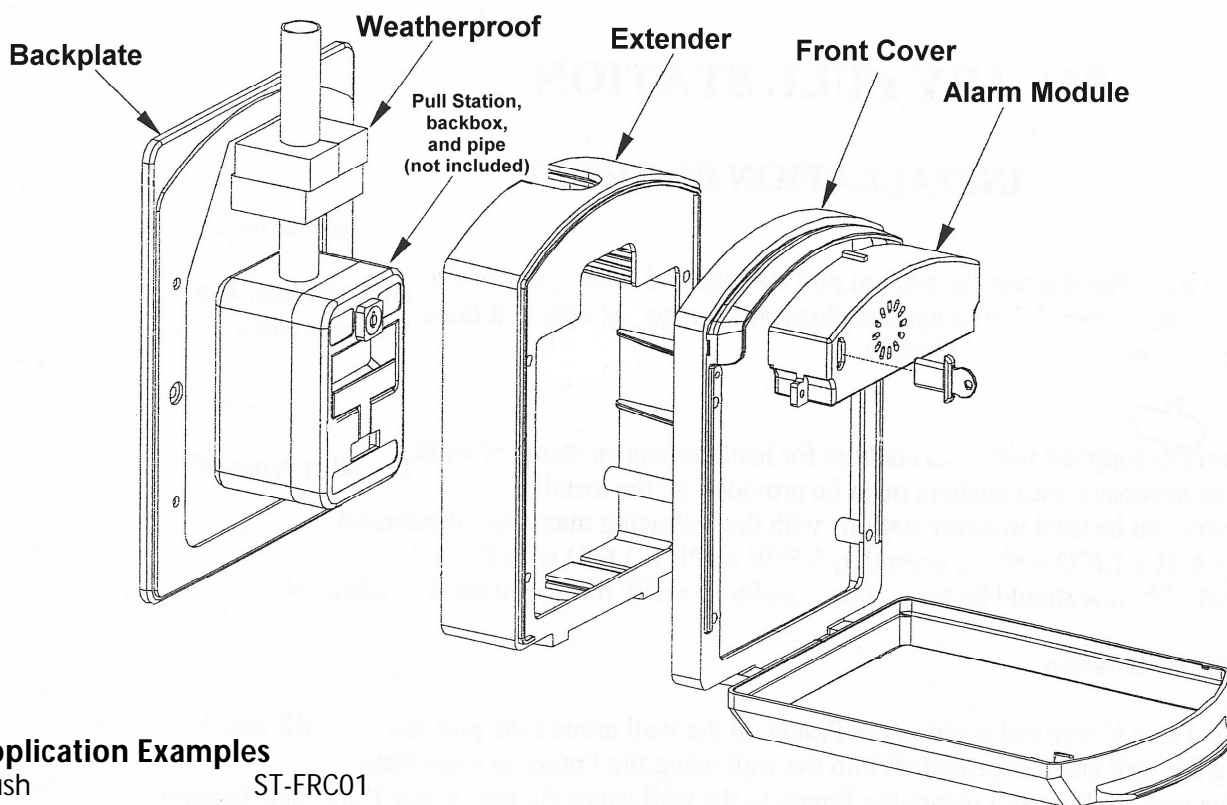

Application Examples

Flush	ST-FRC01
Surface	ST-FRC01, ST-XTR01
Rough Surface	ST-FRC01, ST-XTR01, ST-BKP01
Weather Proof	ST-FRC01, ST-XTR01, ST-BKP01, ST-WPK01
Alarm Module	ST-ALM01
Can be added to any application	

Sentry exterior Dimensions

<u>Part</u>	<u>part number</u>	<u>height</u>	<u>width</u>	<u>depth (from wall)</u>
Front	ST-FRC01	10" high,	7-1/4" wide,	1-3/4" deep
Extender	ST-XTR01	10" high,	7-1/4" wide,	2" deep
Backplate	ST-BKP01	10-1/2" high,	8" wide,	1/4" deep

All depth dimensions added up are actually just less than 4", which is the maximum for ADA Guidelines.

Pull Station maximum Dimensions

Front cover alone	6" high,	5-1/2" wide,	1.6" deep
With Extender	6" high,	5-1/2" wide,	3.6" deep