

The DVS+200 has 4-50Watt amplifier boards that can be configured with 25 or 50Watt output circuits.

By changing the jumpers on the amplifier boards different combinations of 25 and 50Watt speaker circuits can be utilized.

All outputs either 25 or 50W are fully supervised for opens and shorts, selectable for 25 or 70VRMS, with connections for Class A (Style Z) or Class B (Style Y) wiring.

They are power-limited by an Intelligent overload controller that limits the output power but does NOT disconnect the circuit in an overload condition. Thus ensuring that the emergency message will be broadcast, even though at a reduced audio level.

The DVS+200 can also be configured with the DVS+ZM4 Zone Splitter modules to increase the number of speaker output circuits. Refer to the application note AN-DVS+200/16 for pre-engineered systems information.

The 25/50W jumper settings are explained on the AN-DVS+AM50 application note. Detailed information on the DVS+AM50 amplifier board is available on the Installation Instructions #1000-0747.

DVS+200 4 Zones

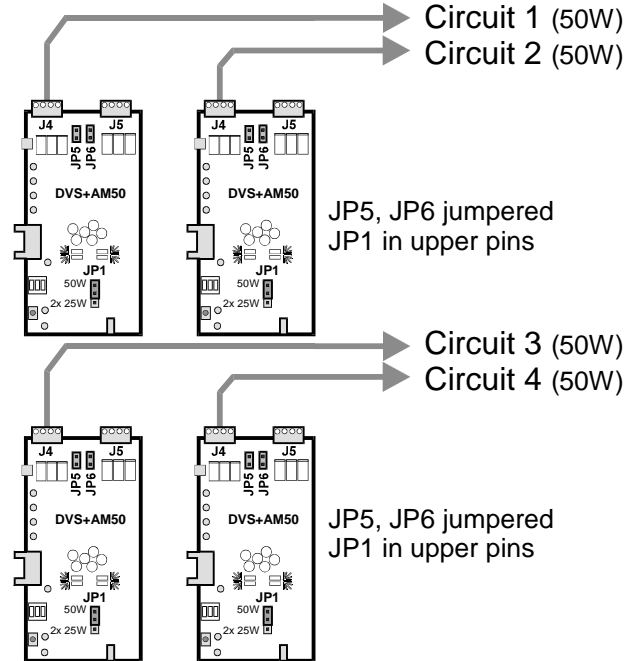

DVS+200 6 Zones

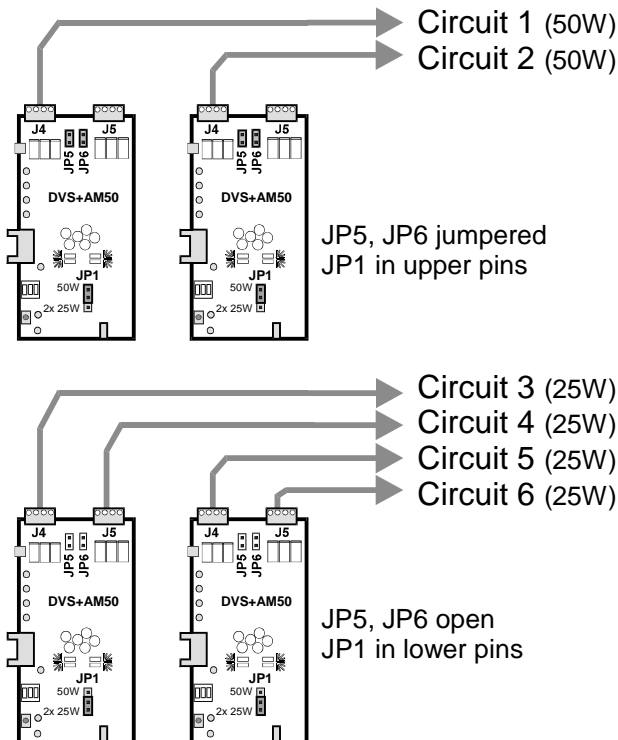

DVS+200 8 Zones

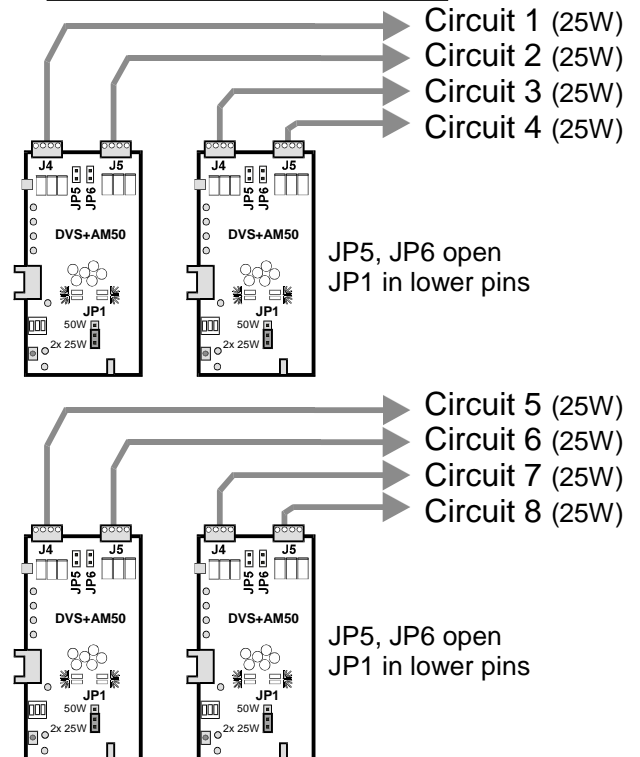

an-DVS+200.cdr 10/04r1cgs

The DVS+200/16 has 4-50Watt amplifier boards and 4-4Circuit Zone Splitters.

By adding one more splitter to the last amplifier, the DVS+200/20 is realized.

All the speaker circuit outputs are fully supervised for opens and shorts, with Class A (Style Z) and Class B (Style Y) wiring available.

The outputs on the Zone splitters are matched for VRMS output to the Amplifier it is attached to.

This provides the correct power limiting setting for the individual speaker circuits.

Individual Zone Splitter circuit outputs are Power Limited to 15Watts.

The total speaker load on any circuit cannot exceed that limit.

The total load on any Zone splitter cannot exceed the power available from it's associated amplifier.

Outputs of the DVS+ZN4 Zone Splitter can be switch selected for zoned paging.

Detailed information on the DVS+AM50 amplifier board is on the Installation Instructions #1000-0747.

Detailed information on the DVS+ZM4 Zone Module is on the Installation Instructions #1000-0748.

Other combinations of Amplifiers and Splitters can be obtained.

Please consult Applications Engineering at the factory for assistance in determining the customized layout.

